



2850C

Madill Log Loader

For over 60 years Madill's purpose built logging equipment has set the standard in performance, productivity and longevity for west coast logging. Madill's heritage of rugged, tried and true forestry machines ensures both reliability and durability for your most demanding logging environments...

...the heritage continues....



Specifications

Engine	Cummins QSC Tier III 8.3 Litre, 300 HP @ 2,200 RPM
Radiator & Oil Cooler	2,100 sq. in. high capacity side by side radiator charge air and oil cooler
Electrical	24 volt 70 amp alternator, 2 - 8D batteries, 8 halogen lights
Hydraulic Pumps	Rexroth variable displacement piston pump, 151 U.S. gal/min 4,500 PSI operating pressure, pilot pump and grapple rotation pump on engine
Valve	Linde Synchron load sense valve provides tuneable multi function capability
Filters	10 Micron return filters mounted in hydraulic tank, 80 mesh suction screen
Speed	2 speed to 3.2 mph
Fuel Tank	Rear mounted Fuel/Oil Tank, capacity: Fuel - 209 U.S. gallon, Oil - 99 U.S. gallon

Boom

Boom	Madill formed plate boom, guards on stick and boom cylinders
Boom Reach	Butt N Top Maximum reach 36' Heel Boom Maximum reach 40'6"
Boom Gross Lift	15' - 45,470 lbs, 20' - 33,460 lbs, 25' - 25,900 lbs 30' - 20,330 lbs, 35' - 14,910 lbs.
Boom Cylinders	KYB: Boom - \varnothing 5.91" Stick - \varnothing 6.69" Heel - \varnothing 5.0"

Weights & Dimensions

Weight	89,000 lbs with attachment
G.P	9.0 PSI
Counterweight	13,500 lbs
Undercarriage	D7HD, 17'0" long x 11'11" wide, 30" double grouser shoes 9 Excavator rollers per side, top track slides, ski type rock guards
Carbody Clearance	30"
Track Dimensions	17'0" long x 11'11" wide
Tractive Effort	77,200 lbs
Tailswing	10'7"



Image: Madill 2850C with Butt N Top

House & Cab

House	Single piece hydraulically raised house c/w tube frame, punched plate grilles, easy access stairway
Cab	Madill 46" rear entry cab, high visibility with bronze tint Lexan floor and side windows, marguard front window, tilt open left hand window, air ride heated seat, arm rests and joystick controls, 53,000 BTU heater, 33,000 BTU air conditioner, emergency exit, dual wipers, AM/FM radio/CD player, DDEC V engine monitor and diagnostic system
Cab Riser	Forward sloped for good visibility, 14' eye level, hydraulic tilt for moving

Swing Mechanisms

Swing Bearing	60" Kayden
Swing Drive	Twin L & S planetary with adjustable free swing
Swing Speed	7.5 RPM
Swing Torque	102,000 ft. lbs

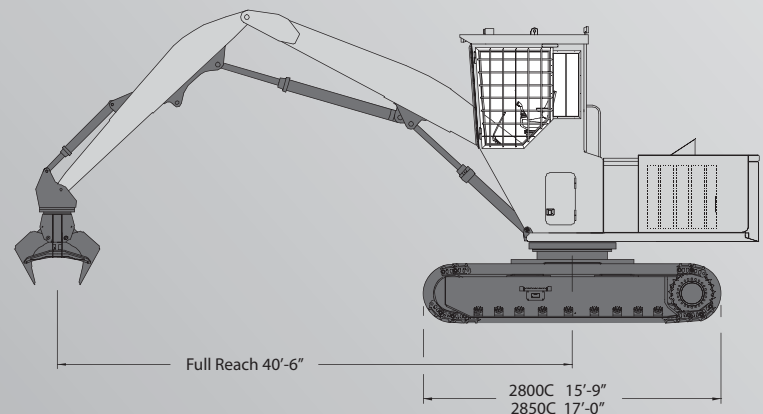

Diagram: Madill 2850C with Butt N Top